

H600



US Patent No. 7,193,428

Hawkeye® 600

Mini Split-Core Go/No Current Switch

Installer's Specifications

Amperage Range	0.2-200A (50Hz) continuous; 0.15-200A (60Hz) continuous
Sensor Supply Voltage	Induced from monitored conductor
Isolation	600VAC rms. (UL) 300VAC rms (CE), for use on insulated conductors only
Temperature Range	-15° to 60°C (0-150A), -15° to 40° C (0-200A)
Humidity Range	10-90% RH non-condensing
Status Output Ratings	N.O. 1.0A@30VAC/DC non-polarity sensitive
Off-state leakage	0 (open switch represents 1 + MEG ohms of resistance)

Specification Note: For CE compliance, conductor shall be insulated according to IEC 61010-1:2001, Installation Category III or equivalent. The product design provides for functional insulation only.

⚠ DANGER ⚡

HAZARD OF ELECTRIC SHOCK, EXPLOSION, OR ARC FLASH

- Follow safe electrical work practices. See NFPA 70E in the USA, or applicable local codes.
 - This equipment must only be installed and serviced by qualified electrical personnel.
 - Read, understand and follow the instructions before installing this product.
 - Turn off all power supplying equipment before working on or inside the equipment.
 - Use a properly rated voltage sensing device to confirm power is off.
- DO NOT DEPEND ON THIS PRODUCT FOR VOLTAGE INDICATION**
- Only install this product on insulated conductors.

Failure to follow these instructions will result in death or serious injury.

NOTICE

- This product is not intended for life or safety applications.
- Do not install this product in hazardous or classified locations.
- The installer is responsible for conformance to all applicable codes.
- Mount this product inside a suitable fire and electrical enclosure.

QUICK INSTALL

1. Plan the installation:
Locate a mounting surface for the removable mounting bracket that will allow the monitored conductor to pass through the iris, or "window" when it is installed and keep the product at least 1/2" from any uninsulated conductors (CE). Determine cable routing for the controller connection, allowing wiring to reach the mounting location.
2. Install mounting bracket
Drill holes to mount the bracket to the chosen surface using the included screws.
3. Wire the output connections between the sensor and the controller (solid-state contact).
4. Snap the sensor over the wire to be monitored and clip the assembly to the mounting bracket.
5. Close up and power up!

DIMENSIONS

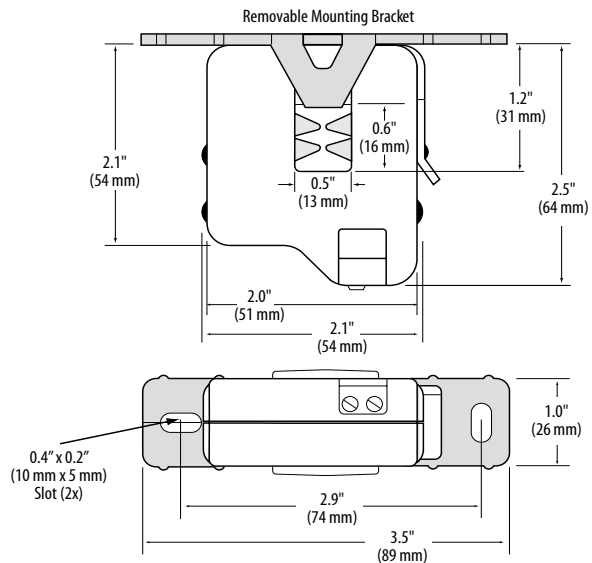

Wiring Example

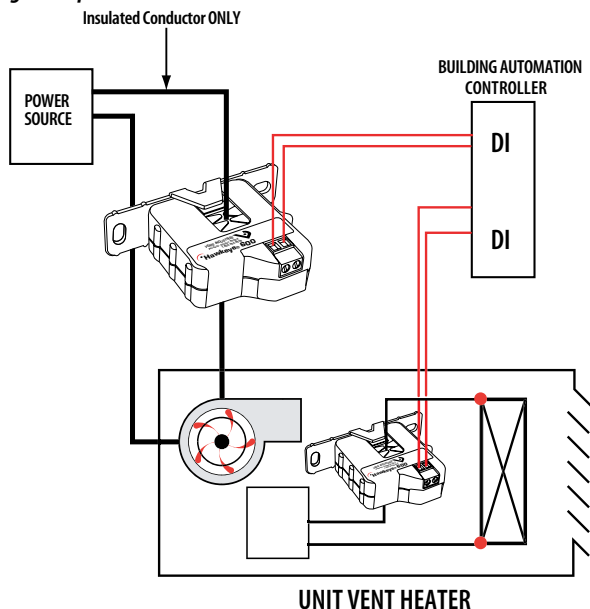

OPERATION

The H600 is a current-sensitive switching device which monitors current (amperage) in the conductor passing through it. A change in amperage in the monitored conductor which crosses the switch threshold will cause the resistance of the status output to change state, similar to the action of a mechanical switch. In this model, the threshold is fixed at 150mA AC max (200mA AC for 50Hz operation). The status output is suitable for connection to building controllers, or other appropriate data acquisition equipment operating at up to 30 volts. The H600 requires no external power supply to generate its output.

NOTES

For load currents greater than sensor maximum rating:

Use a 5 Amp (H681x series) Current Transformer (CT) as shown.

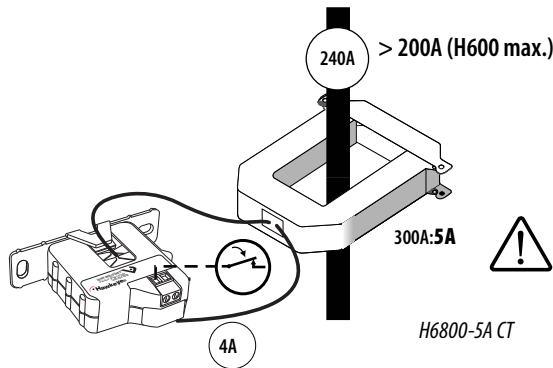

TROUBLESHOOTING

Problem	Solution
No Reading at Controller	<ul style="list-style-type: none"> • Check for control voltage at sensor (<30V) • Check for amperage in monitored conductor (> 0.15A@60Hz) • Assure that sensor core mating surfaces are clean and that the core clamp is completely closed

! DANGER: 5A CTS CAN PRESENT HAZARDOUS VOLTAGES. INSTALL CTS IN ACCORDANCE WITH MANUFACTURER'S INSTRUCTIONS. TERMINATE THE CT SECONDARY BEFORE APPLYING CURRENT.

CAUTION

RISK OF EQUIPMENT DAMAGE

- Derate the product's maximum current for the number of turns through the sensing window using the following formula.

$$\text{Rated Max. Amps} \div \text{Number of Turns} = \text{Max. monitored Amps}$$
 e.g. : 100A ÷ 4 Turns = 25 Amps max. in monitored conductor
- Failure to follow these instructions can result in overheating and permanent equipment damage.

For load currents less than sensor minimum rating:

Wrap the monitored conductor through the center hole and around the sensor body to produce multiple turns through the "window." This increases the current measured by the transducer.

- Controller must be programmed to account for the extra turns. e.g., if four turns pass through the sensor (as shown) the normal threshold current must be divided by 4.

